



# Monitored Retro-Reflective Photo-eye

Ideal for heavy duty applications

This versatile, reflective photo-eye is designed to withstand the challenges of heavy duty commercial and industrial applications.

- UL325:2010 – recognized photo-eye
- NEMA 4X – rated for harsh environment protection
- Heavy duty housing – provides extra durability
- Polarized beam and high range – for maximum reliability in signal reception
- Retro-Reflective technology – is resilient to ambient light and infrared sensors
- Adjustable design – allows for installation flexibility



## Interference reduction technology

Red light technology reduces interference from ambient lighting and infrared sensors often encountered around industrial door openings. In addition the monitored Retro-Reflective Photo-eye features technology that enables these sensors to further reduce interference from reflective surfaces.

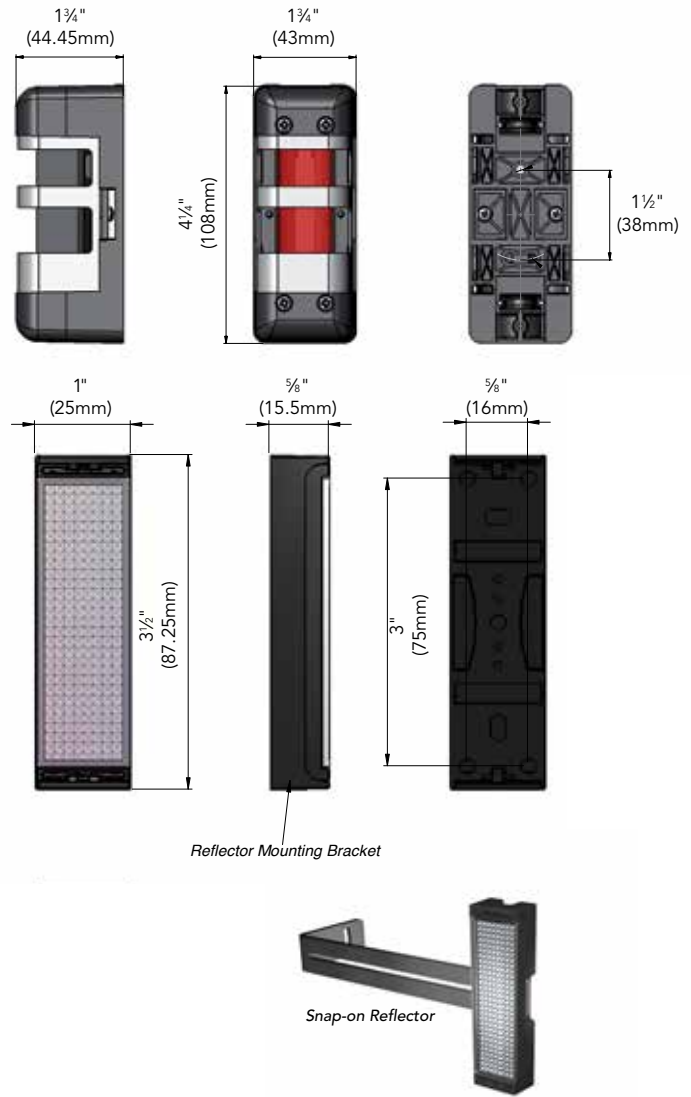

## Typical installation

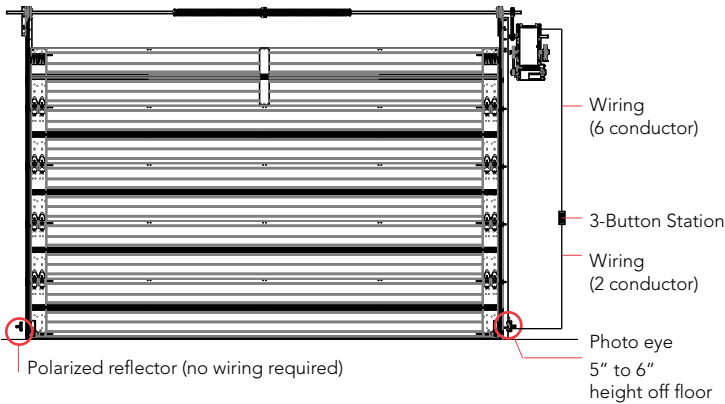

## Technical Information

Range/working distance	5 ft. to 35 ft. (1.6 m to 10.6 m)
Protection class	IP65, NEMA 4X
Operation temperature	-22° F to + 140° F (-30° C to +60° C)
Dimensions	1 3/4" x 4" x 1 3/4" (43 mm x 100 mm x 45 mm)
Reflector dimensions	1" x 3 1/2" x 1/2" (25 mm x 87 mm x 15 mm)
Power consumption	Max. 40 mA
Terminal interface	Monitored 2-Wire
Connection cable	6 1/2 ft. (2 m) cable, fine stranded, wire size 24 (0.25 mm <sup>2</sup> ) AWG

**Overhead Door Corporation**  
 2501 S. State Hwy. 121 Bus., Suite 200  
 Lewisville, Texas 75067  
 1-800-929-DOOR • [www.OverheadDoor.com](http://www.OverheadDoor.com)